

## FERITSCOPE® DMP30

Instrument for measurement of the ferrite content in austenitic and duplex steel



DISTRIBUÉ PAR / DISTRIBUTED BY:

**QNDE**  
QUALITY NDE LTD

**QUEBEC**

164, St-Jean-Baptiste  
Mercier, QC J6R 2C2  
450-691-9090  
info@qn.de.ca



**ONTARIO**

275, Sheldon Drive, Unit 3  
Cambridge, ON N1T 1A3  
519-894-9069  
nadams@qn.de.ca

**ALBERTA**

7307, 50 street NW  
Edmonton, AB T6B 2J9  
587-689-6811  
lfields@qn.de.ca

[www.qn.de.ca](http://www.qn.de.ca)

1-800-361-3630

**fischer**®

# FERITSCOPE® DMP30

## Description

The FERITSCOPE® FMP30 determines the delta-ferrite content of austenitic and Duplex steels using the magnetic inductive test method. All magnetizable structure sections are captured i. e., in addition to delta-ferrite also strain-induced martensite, for example, or other ferritic phases. Areas of application are onsite measurements, e.g. of austenitic platings as well as weld seams in stainless steel pipes, containers, boilers or other products made of austenitic or duplex steel.

## Properties

- Suitable for measurements according to the Basler Standard
- Already from a plating thickness of 3 mm the ferrite content can determine without substrate influence
- Measurement range, trueness and repeatability are dependent on the connected probe. You will find this data in the respective probe data sheet.
- Uniform, simple and convenient operation
- Only one calibration required for entire relevant measurement range from 0.1 to approx. 90 FN; calibration to reference value or by customer-specific calibration standards; adherence to the measurement accuracy specified in standards ANSI / AWS A4.2M / A4.2:1997
- Calibrations for various applications are storable in and recallable from the connected probe
- USB and Bluetooth® interface
- Compact and robust aluminium case with protection code IP54
- Battery rechargeable in the gage

## Applications

- Determination of delta-ferrite content of austenitic and duplex steel
- determination of deformation martensite in austenitic materials
- Finding weld seams in polished surfaces
- Capturing a ferrite content profile along the weld seam

## Metrological Features

### Measurement acquisition

- Default: After each placement of the probe onto the surface a measured reading is automatically recorded
- Scan mode: While probe is moving over the surface the measured readings are automatically recorded according to the defined time interval and number of measurements.

### Indication of measurement acquisition

- Audible by a short beep, on/off switchable
- Visual by colored illuminated stripe (green: measured value recorded)
- Haptic by gage vibration, on/off switchable
- Limit violation: 2 short beeps, red illuminated stripe and gage vibration
- Measured reading between the limits: 1 short beep, green illuminated stripe and gage vibration

### Measurement performance

Measurement speed, measurement range, trueness etc. depend of the connected probe, you will find these data in the respective probe data sheet

### Storage of measured readings

on/off switchable

### Measurement unit

FN oder Fe%

### Offset value/ correction value

Settable, is deducted automatically from the measured reading.

### Resolution of the displayed values

- Low (up to 1 decimal place)
- Medium (up to 2 decimal places)
- High (up to 3 decimal places)

### Measurement modes

#### ■ Single Reading

After each placing of the probe the measuring reading is displayed and stored automatically in the gage.

#### ■ Free Running

After placing the probe on the surface the continuous display of the measured readings appears without automatic storage, useful for quick checking of coating thicknesses over a defined surface area, e.g. in tank construction

#### ■ Scan

The Scan mode allows a defined recording of the measurement acquisition while the probe is moving over the surface. You can set the number of single readings and the time interval for the measurement acquisition in the gage. Useful to determine the coating thickness over surface areas.

### Grouping measured readings

Settable block (group) size between 1 and 1000 single readings

### Limit monitoring

On/Off switchable; limit values settable

# FERITSCOPE® DMP30

## Calibration

The measuring system (gage and connected probe) needs reference values as relation for determining the ferrite content. This adjustment is carried out by a calibration (normalization). Calibrations with customer-specific calibration standards or correction factors (included manual) can be used to take influences of the specimen shape (strong curvature), plating and substrate thicknesses into account. Furthermore, the gage contains a function (Quick) for semi-automatic calibration.

### Calibration method

Adjustment of the measuring system (gage and connected probe) to a zero point (base) and adjustment to up to two ferrite content values by using calibration standards. On recalibration, individual calibration steps can be skipped.

### Store calibrations

The storage location for a calibration depends of the connected probe.

- Digital probe: up to 100 calibrations can be stored in the connected digital probe; probe identifiable by the USB-C female jack and by the probe name, beginning always with the letter D
- Analog probe: connection via DMP-F-probe-Adapter plugged into the gage; total up to 100 calibration can be stored in the DMP-F-Probe-Adapter; only the calibrations that were created with the probe connected to the DMP-F-Probe-Adapter are available in the gage in each case; probe identifiable by the 10-pin male jack and by the probe name, beginning always with the letter F

### Calibration check

Checking the calibration state of the selected calibration and the measuring accuracy of the measuring system. You can check whether the mean value of the check measurement matches the reference value of the calibration standard to within the scope of measurement uncertainty (in accordance with ISO/IEC Guide 98-3).

### Lock calibrations

You can lock selected calibrations.

### Ways of air reference value acquisition

During measurement, the air reference value is used to reference the zero point determination. Regular measurement of the air reference value is necessary to achieve high measurement accuracy. This is done automatically in the measurement mode Single Reading when the probe is lifted off from the surface.

- Default in Probe: air value acquisition as factory predefined in probe (Dynamic/Static)
- Dynamic: automatic acceptance of the air value always when the gage probe is lifted from the surface, default mode
- Static: no automatic acceptance. The air reference value must be measured manually at regular intervals. This may be useful for automated measurements or manually triggered measured reading acceptance, if the positioning of the gage probe requires some time, e.g. for measurements in small cavities.

## General Features

---

### Measurement views

- Simple: the measured reading with the set measurement unit is displayed only; additionally with display of the limit values if set
- Statistics: the measured reading with tabular measurement statistics

### Languages

Many different display languages, beside German and English several other European and Asian languages

### Date & Time

- settable
- Date and time formats settable (TT.MM.JJ or MM/TT/JJ and 12 h or 24 h)

### Storage space

- Number of batches:  $\leq 2\,500$
- Total number of measured readings:  $\leq 250\,000$
- Number of blocks per batch:  $\leq 10\,000$
- Number of measured readings per block:  $\leq 10\,000$

### Evaluation

- Batch statistics, over-all evaluation over all stored measured readings of one batch
- Block statistics, Evaluation over the grouped measured readings, evaluation per block
- Graphic presentation of measured readings, histogram over all measured readings of one batch, from 30 readings

### Datentransfer

- via USB
- via Bluetooth®
- Data export via Fischer Data Suite to Excel® (online, offline)
- Data retrieval by Fischer DataSuite: batches, single readings, batch statistics and block statistics

### Test method

on basis of DIN EN ISO 2178 / ASTM D7091 Magnetic induction test method

### Connectable probes

- Digital probes with USB-C female jack, probe names beginning always with the letter D
  - via DMP-F-Probe-Adapter analog probes with 10-pin male jack, probe names beginning always with the letter F
- Each individual probe is factory-calibrated at several reference points with the greatest care to ensure the highest possible degree of trueness.

### Energy management

- **Power supply:** Li-Ion rechargeable battery, model RRC1130  
Nominal voltage: 3.8 V=  
Nominal capacity: 3880 mA, 14.7 Wh  
max. charge voltage: 4.35 V=  
max. charge current: 2.4 A
- **Battery operating period**  
> 24 h with continuously measurement and about +20 °C (+68 °F) ambient temperature

# FERITSCOPE® DMP30

## ■ Battery charging time

- about 6 h by default
- about 3 h for fast charging

---

## Protection class

IP54

---

## Admissible climatic conditions during storage and transport

we recommend to store and transport battery and gage separately

- Gage without Li-Ion rechargeable battery
  - Ambient temperature: 0 ... +50 °C (+32 ... +122 °F)
  - Relative humidity: 5 ... 85 %RH at 25 °C (+77 °F), non-condensing
- Li-Ion rechargeable battery, model RRC1130
  - Ambient temperature: -20 ... +20 °C (-4 ... +68 °F)
  - Relative humidity: 40 ... 60 %RH, non-condensing

---

## Admissible climatic conditions during operation

- Ambient temperature: 0 ... +50 °C (+32 ... +122 °F)
- Relative humidity: 5 ... 85 %RH at 25 °C (+77 °F), non-condensing
- Altitude of location: up to 2000 m (6561.7 ft) (above sea level)
- Pollution degree: 3

---

## Optical indications

- Graphical display with automatic flip view (off switchable) allows optimum reading in different measuring positions
- Colored illumination stripe to signal measurement acquisition, limit violation and battery charging status

---

## Connections

- 2 USB female jacks, type C
  - USB 3.1, 900 mA/5 V=: for connecting digital probe ■ for fast charging the Li-Ion rechargeable battery in the gage
  - USB 3.1, 500 mA/5 V=: for charging the Li-Ion rechargeable battery in the gage ■ for connection to a PC for data transfer ■ max. cable length: 3 m (118 inches)
- USB socket, type A
  - Specific for inserting Fischer Bluetooth® stick for data transfer via Bluetooth®
  - Fischer Bluetooth® stick (scope of supply): Bluetooth v 4.0. LE, transmit power up to -27 dBm

---

## Weight

Gage with rechargeable battery: 276 g (0.61 lb)

## Dimensions

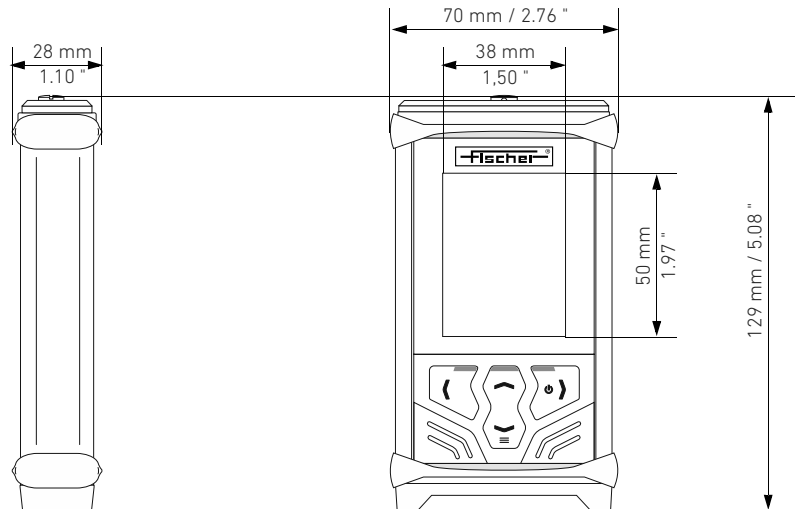

## Scope of supply

Gage, Li-Ion rechargeable battery, USB cable type C to type A (1 m/39.4"), Quick Guide, lanyard, gage case, Fischer Bluetooth® stick

## Order Information

### Gage

- Order number: 1007334

### Accessories/Spare parts

- manufacturer's Certificate: in conjunction with probe only, see probe data sheet
- Evaluation an archiving software Fischer DataSuite: free of charge download, you will find download link in operator's manual
- DMP-F-Probe-Adapter: 1007336  
for connecting analog F-probes with 10-pin connection plug
- USB cable: 206-139  
type C to A, 1 m (39.4")
- Fischer Bluetooth® stick: 1005529  
Bluetooth v 4.0. LE, transmit power up to -27 dBm
- Li-Ion rechargeable battery, model RRC1130: 1005530
- Charger for Li-Ion rechargeable battery, model RRC1130: 1007860
- Gage foot: 1005837
- Battery compartment cap: 1007162

You must order the probe separately. Call us, we are gladly support you with the selection.

# FERITSCOPE® DMP30

DISTRIBUÉ PAR / DISTRIBUTED BY:



## QUEBEC

164, St-Jean-Baptiste  
Mercier, QC J6R 2C2  
450-691-9090  
info@qn.de.ca

## ONTARIO

275, Sheldon Drive, Unit 3  
Cambridge, ON N1T 1A3  
519-894-9069  
nadams@qn.de.ca

## ALBERTA

7307, 50 street NW  
Edmonton, AB T6B 2J9  
587-689-6811  
lfields@qn.de.ca



[www.qn.de.ca](http://www.qn.de.ca)

1-800-361-3630

*DELTA SCOPE®, ISO SCOPE® and DUAL SCOPE® are registered trade marks of the Helmut Fischer GmbH Institut für Elektronik und Messtechnik in Germany and other countries.*

*Excel® is a registered trade mark of the Microsoft Corporation, USA. Bluetooth® is a registered trade mark of the Bluetooth SIG, USA.*

*Note: Designations not marked with ® or ™ may also be protected by law.*

[www.helmut-fischer.com](http://www.helmut-fischer.com)

**fischer**®